

KENT WELDING GUN



MADE IN CANADA
BUILT FOR WELDERS

KENT ONE GUN

ONE GUN YOUR WAY

Custom MIG Guns To Fit Your Needs

- 200, 300, 400 & 500 amp options
- Custom gun body lengths & bends
- Miller, Lincoln, Tweco, Euro connections
- Designed for comfort and durability
- No catalogue limitations

WE ARE SOLUTIONS

1249 Plessis Road
Winnipeg, MB R2C 3L9 Canada

PHONE: 1.800.427.0430

EMAIL: sales@kentweldinggun.com

WEB: kentweldinggun.com



Build Your Gun in 5 Steps:	Example One Gun Part# build:
Step 1: Choose Your Gun Style	OGH
Step 2: Select Your Amperage	OGH-4
Step 3: Choose Your Length (<i>built to your spec if needed</i>)	OGH-4-15
Step 4: Select Your Power Pin Connection	OGH-4-15M
Step 5: Customize Your Setup (<i>if required</i>)	s/up: 02-023-6, 408-045, 03-524, 401-6-62, 44315

Custom Gun Bodies – Gun Lengths and Setups. No Headaches.

If your application is unique, contact us and we'll build it to match – without any long delays

Gun Style	Gun Body	Amperage	Length	Power Pin Connection
(Kent consumables) OG-	1/2" Gun Body	2-	200amp	10- M Miller
(Kent consumables) OGH-	9/16" Gun Body	3-	300amp	12- K Kent
(Bernard consumables) OGB-	1/2" Gun Body	4-	400amp	15- T T4
(Bernard CF consumables) OGHB-	9/16" Gun Body	5-	500amp	20- L Lincoln
(Tregaskiss consumables) OGHTG-	9/16" Gun Body			25- E Euro
(Tweco consumables) OGHTW-	9/16" Gun Body			

Electrical Plug Options:			
01-001-182M - Miller	01-001-182L - Lincoln	01-001-182E - ESAB	182M - Kent (standard)





Standard configurations shown below. Need something different? We'll build it.					Liner (based on plug-end)	
Style-Amp xx-Length i-Power Pin	Gun Body	Contact Tip	Gas Head	Nozzle	M, K, E	T, L
OG-2-xxi	02-021-4	408-035	03-424	401-4-62	43115	44-3545-15
OG-3-xxi	02-021-5	408-035	03-424	401-6-62	43115	44-3545-15
OG-4-xxi	02-021-6	408-045	03-424	401-6-62	44315	44-116-15
OGB-2-xxi	02-021B-4	408-035	03-424B	401-4-62	43115	44-3545-15
OGB-3-xxi	02-021B-5	408-035	03-424B	401-6-62	43115	44-3545-15
OGB-4-xxi	02-021B-6	408-045	03-424B	401-6-62	44315	44-116-15
OGH-2-xxi	02-023-4	408-035	03-524	401-6-62	43115	44-3545-15
OGH-3-xxi	02-023-5	408-035	03-524	401-6-62	43115	44-3545-15
OGH-4-xxi	02-023-6	408-045	03-524	401-6-62	44315	44-116-15
OGH-5-xxi	02-023-8	408-062	03-524	401-6-62	44315	44-116-15
OGHB-2-xxi	02-023B-4	408-035	03-424B	401-6-62	43115	44-3545-15
OGHB-3-xxi	02-023B-5	408-035	03-424B	401-6-62	43115	44-3545-15
OGHB-4-xxi	02-023B-6	408-045	03-424B	401-6-62	44315	44-116-15
OGHB-5-xxi	02-023B-8	408-062	03-424B	401-6-62	44315	44-116-15
OGHTG-2-xxi	02-023-4	408T-035	404-3	401-6-62	43115	44-3545-15
OGHTG-3-xxi	02-023-5	408T-035	404-3	401-6-62	43115	44-3545-15
OGHTG-4-xxi	02-023-6	408T-045	404-3	401-6-62	44315	44-116-15
OGHTG-5-xxi	02-023-8	408T-062	404-3	401-6-62	44315	44-116-15
OGHTW-2-xxi	02-023T-5	14H-35	54A	24A62	43115	44-3545-15
OGHTW-3-xxi	02-023T-5	14H-35	54A	24A62	43115	44-3545-15
OGHTW-4-xxi	02-023T-6	14H-45	54A	24A62	44315	44-116-15
OGHTW-5-xxi	02-023T-8	14H-62	54A	24A62	44315	44-116-15



LINER CHART

Direct Plug Connection	15' Liners	20' Liners	25' Liners	Wire sizes
09-453M 	43015			.023-.030
	43115	43120	43125P	.035-.045
	44115P	44120P	44125P	.035-.045
	44315			.045-.062
	44315P	44320P	44325P	.045-.062
			45325P	.062-.110
	435-15			.045-.078
	535-15			.078-.125
	**44315T			.045-.062
	*43115X			.035-.045
	*44315X			.045-.062

Direct Plug Connection	15' Liners	20' Liners	25' Liners	Wire sizes
09-453T 09-453L 	42-3035-15			.023-.030
	44-3545-15	44-3545-20	44-3545-25P	.035-.045
	44-045-15P	44-045-20P	44-045-20P	.035-.045
	44-116-15			.045-.062
	44-116-15P	44-116-20P	44-116-25P	.045-.062
			44-221-25P	.062-.110
	435T-15			.045-.078
	535T-15			.078-.125
	**44-116-15T			.045-.062
	*44-3545-15X			.035-.045
	*44-116-15X			.045-.062

Direct Plug Connection	15' Liners	20' Liners	25' Liners	Wire sizes
09-453TG 	415-3545-15	415-3545-20	415-3545-25P	.035-.045
	415-045-15P	415-045-20P	415-045-25P	.035-.045
	415-116-15			.045-.062
	415-116-15P	415-116-20P	415-116-25P	.045-.062
			415-221-25P	.062-.110
	435TG-15			.045-.078
	**415-116-15T			.045-.062
	*415-3545-15X			.035-.045
	*415-116-15X			.045-.062

* nylon liner material (aluminum)

** teflon liner material (yellow)

> ALL Liners ending with "P" denotes Premium Liner material

KENT WELDING GUN

200 – 300 – 400 – 500 AMP AIR COOLED GMAW GUN

ONE GUN PARTS LIST

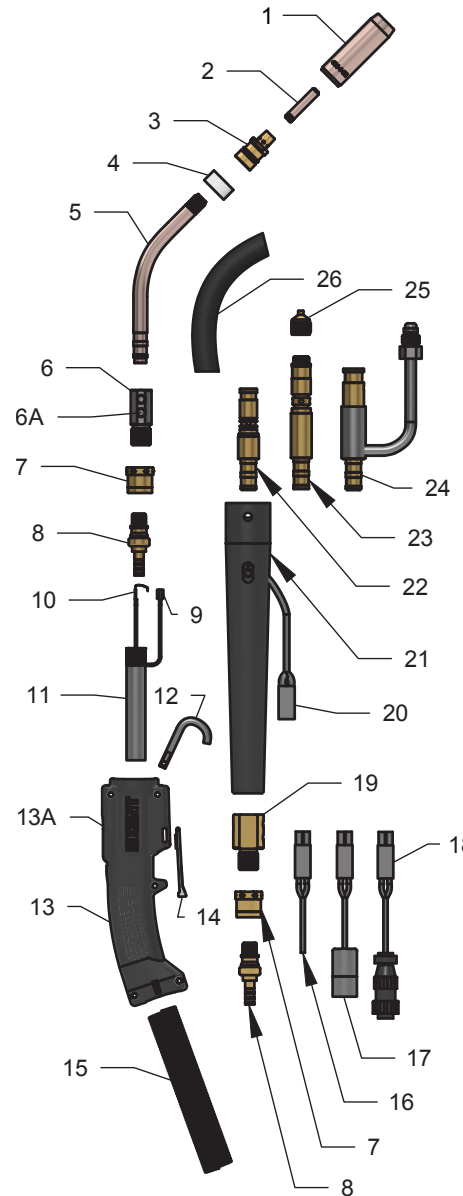

ID	OG	OGH	DESCRIPTION
1			see chart Nozzle
2			see chart Contact Tip
3			see chart Gas Head
4	02-420	02-520	Cap
5	02-021	02-023	Gun Body
6	02-003	05-003	Body Block
6A		02-110	Block Screw
7		02-041	Power Cable Nut
8	02-046	05-046	Power Cable End
9		02-015	Terminal
10		02-017	Switch Spring
11		200/300/400/500	Power Cable
12		09-074	Hook
13		09-200	Handle
13A		09-205	Cover Kit
14		02-016	Switch Lever
15		429S	Spring Support
16		182M	Lead Wire
17		01-001-182L	Lincoln Plug
18		01-001-182M	Miller Plug
19		09-005	Rear Block
20		182F	Lead Wire
21		09-754	Rear Support
22		09-453T	T4 Direct Plug
23		09-453M	Miller Direct Plug
24		09-453L	Lincoln Direct Plug
25		09-019	Wire Guide
26	02-013	05-013	Body Insulator

1249 Plessis Road, Winnipeg, Manitoba R2C 3L9 Canada

PHONE: 204.667.7555 • TOLL-FREE: 800.427.0430

sales@kentweldinggun.com

www.kentweldinggun.com



Proudly
Made in Canada

KENT ONE GUN - CONSUMABLES CHART

Gun Type	Gun Body	OD	Gas Head	Contact Tip	Nozzle (see chart)
OG	02-021-4	1/2"	03-424	408-xxx	401-series
	02-021-5		03-424	408P-xxx	401-40-38; 401-42-50
	02-021-6		03-425F	14-30	401-series
	02-021-8		03-424M8	150-xx-130	401-series
			03-424M10	150-xx-403	401-series
			424	408-xxx	403; 403B
			426	408-xxx	402; 402B



Gun Type	Gun Body	OD	Gas Head	Contact Tip	Nozzle (see chart)
OGB	02-021B-4	1/2"	03-424B	408-xxx	401-series
	02-021B-5		03-424B	408P-xxx	401-40-38; 401-42-50
	02-021B-6		4335	74-series	4391; 4392
	02-021B-8		4435	74-series	403; 403B
			426B	408-xxx	402; 402B
			03-424B-M8	150-xx-130	401-series
			03-424B-M10	150-xx-403	401-series



Gun Type	Gun Body	OD	Gas Head	Contact Tip	Nozzle (see chart)
OGH	02-023-4	9/16"	03-524	408-xxx	401-series
	02-023-5		03-524	408P-xxx	401-40-38; 401-42-50
	02-023-6		524	408-xxx	403; 403B
	02-023-8		03-524M8	150-xx-130	401-series
			03-524M10	150-xx-403	401-series
	02-023-10		524IW	605-xxx	403



Gun Type	Gun Body	OD	Gas Head	Contact Tip	Nozzle (see chart)
OGHTG	02-023-4	9/16"	03-524TL	408-xxx	401-series
	02-023-5		404-3	408T-xxx	401-series
	02-023-6		404-13	408T-xxx	401-series
	02-023-8		03-524M8	150-xx-130	401-series
	02-023-10		03-524M10	150-xx-403	401-series



Gun Type	Gun Body	OD	Gas Head	Contact Tip	Nozzle (see chart)
OGHB	02-023B-4	9/16"	03-424B	408-xxx	401-series
	02-023B-5		03-424B	408P-xxx	401-40-38; 401-42-50
	02-023B-6		4335	74-series	4391; 4392
			4435	74-series	403; 403B
	02-023B-8		03-424B-M8	150-xx-130	401-series
			03-424B-M10	150-xx-403	401-series



Gun Type	Gun Body	OD	Gas Head	Contact Tip	Nozzle (see chart)
OGHTW	02-023T-5	9/16"	54A	14-xxx	Tweco style
	02-023T-6			14H-xxx	24A62
	02-023T-8				34CT w/ 24CT62
	02-023T-10				



xxx = indicate your wire size

NOZZLE CHART

Ref#	Part#	Nozzle ID	Tip Recess
	<i>Standard / Tapered</i>		
#1	401-4-50	1/2"	1/8"
#2	401-4-62	5/8"	1/8"
#3	401-40-38	3/8"	1/8"
#4	401-42-50	1/2"	1/8"



#1 #2 #3 #4

Ref#	Part#	Nozzle ID	Tip Recess
	<i>Heavy-duty</i>		
#5	401-5-62	5/8"	1/4"
#6	401-5-75	3/4"	1/4"
#7	401-6-50	1/2"	1/8"
#8	401-6-62	5/8"	1/8"
#9	401-6-75	3/4"	1/8"



#5 #6 #7 #8 #9

Ref#	Part#	Nozzle ID	Tip Recess
	<i>Kent Original</i>		
#10	402	5/8"	1/8"
#11	402B	1/2"	1/8"
#12	403	3/4"	1/8"
#13	403B	5/8"	1/8"



#10 #11 #12 #13

Ref#	Part#	Nozzle ID	Tip Recess
	<i>Bernard style</i>		
#14	4391	5/8"	1/8"
#15	4392	1/2"	1/8"
	<i>Tweco style</i>		
#16	34CT	n/a	n/a
#17	24CT62	5/8"	1/8"
#18	24A62	5/8"	1/8"



#14 #15 #16 #17 #18

WARNING! Read All Safety Instructions Before Use

Electrical Shock Can Kill

- Always disconnect power source before installing or removing welding gun or changing tips and nozzles

ARC Rays can Burn Skin and Damage Eyes

- Always wear an approved welding helmet with proper grade filter lens.
- Always wear protective gloves & clothing to cover exposed skin from UV and spatter burns

Gases and Fumes can be hazardous to your health

- Ensure proper ventilation or exhaust is used to keep gases and fumes from your breathing zone.
- Wear an OSHA approved breathing respirator or mask

Excessive Noise can cause hearing damage

- Always wear protective hearing devices when noise levels exceed OSHA Standards